

Research on Fast Transient Pulse Group Suppression Filter

Pan Lv*

Dalian University of Technology, Dalian City, Liaoning, 116600, China

Abstract: With the popularization of electronic products, the electromagnetic compatibility problem of electronic equipment is more and more prominent. The suppression of electric fast transient burst (EFT / B) generated by switching power supply is an important research content. Based on the principle of EFT / B, this paper analyzes the basic principles and methods of EFT filter design, and uses the "negative parameter cancellation method" to deal with the design of the filter according to the parasitic parameters of the components that make up the filter Sexual adjustment, to achieve effective suppression of EFT / B noise purposes.

Keywords: EFT / B; Filter; Parasitic parameters

***Corresponding author:** Pan Lv. No.31 West Tieshan Road, economic and Technological Development Zone, Dalian City, Liaoning Province, China. E-mail: 331997967@qq.com

DOI: <http://dx.doi.org/10.26549/met.v1i1.323>

1. Introduction

With the development of society, a large number of electrical equipment in various fields have been applied, power equipment has become more sophisticated, the electricity environment and the quality of electricity requirements are getting higher and higher. Among them, in the process of switching power supply generated by the electric fast transient burst (EFT/B) noise interference, is an important part of the study.

Figure 1 is a schematic diagram of an electrical fast transient burst generator provided in the International Electrotechnical Commission (IEC) in an electrical fast transient burst immunity experiment, which is used for electromagnetic compatibility immunity experiments to simulate The switching of the small inductive load, the switching of the high voltage switch device, and the contact of the relay contact, etc., of the EFT / B interference signal.

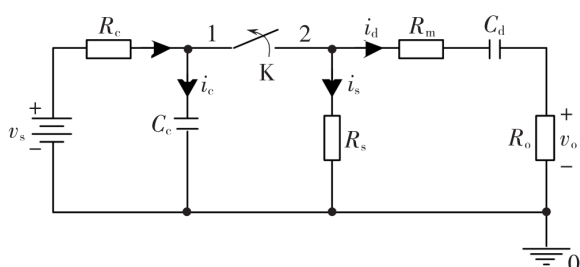

Figure 1. Electric fast transient burst generator analog circuit

2. EFT / B Conventional Suppression Method and Filter Design

Electrical fast transient pulse group interference will allow the use of electrical equipment to be misused, and even damage the electrical equipment circuit, and because of this interference high frequency or ultra-high frequency components, it is the focus of equipment manufacturers to control objects. After years of research by engineering and technical personnel, in the practical application, adding ferrite ring in the power interface is the simplest way to suppress EFT / B noise, ferrite is generally made of hollow round, wrapped around with the enameled wire , When the current containing EFT / B interference passes, the lower frequency of the current will be basically without loss through, but the high frequency current (including EFT / B interference) through the ferrite, because the ferrite through the high frequency current Resulting in a lot of heat, and then the high-frequency current loss, so that you can suppress high-frequency interference to a certain extent, including EFT / B interference signal. However, in practical applications, this simple method does not guarantee the effective suppression of EFT / B interference, so the design of EFT / B filter becomes particularly important, EFT / B filter shown in Figure 2.

The filter capacitor capacitance of the value of the filter has a great impact on filtering effect, after a lot of engineering experiments, the filter C1 and C2 capacitor value

of 18-23nF, C3 and C4 capacitor value of 5-6nF, a total of Modular chokes use inductance N1 and N2 values of 2mH or so, in this range of inductors and capacitors formed by the filter to suppress EFT noise interference effect is better. However, after the engineering practice and related theoretical analysis, the filter still has some limitations, mainly on the concept of "parasitic parameters" fails to be taken in account in the design of the filter, resulting in the filter work at a higher frequency, still existing Filtering ineffective situation.

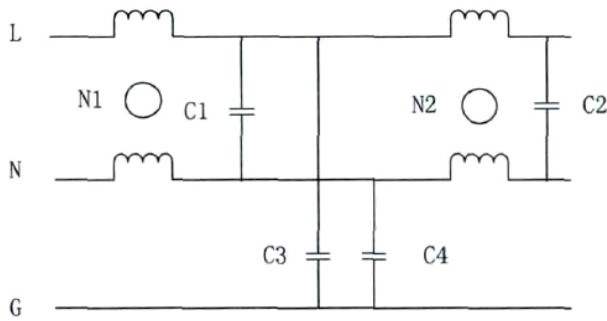

Figure 2. EFT / B filter structure circuit diagram

Because the composition of the filter inductance, capacitance is not the ideal component, and with the surrounding environment also have mutual influence, so through theoretical analysis, so the actual composition of the filter inductance can be equivalent to an ideal inductance L, and EPC (equivalent parallel capacitance) and EPR (equivalent parallel resistance) in parallel (as shown in Figure 3), where EPC is the inductance coil winding and the surrounding parasitic capacitance generated, EPR is composed of inductance coil wire, coil winding core and the capacitor can be equivalent to an ideal capacitor C, ESR (equivalent series resistance) and ESL (equivalent series inductance) in series (as shown in Figure 4), and the equivalent resistance of the capacitor considering the loss, ESL is the equivalent inductance of the capacitor and the corresponding lead, the equivalent parameters are in the composition of the filter capacitor and the actual work of the inductor itself, so we in the design of the filter, the need to eliminate and improve the filtering effect of the filter.

3.Parasitic Inductance and Parasitic Capacitance Elimination

3.1 Capacitive Parasitic Inductance Suppression

Figure 5 is the parasitic inductance eliminator of the electrical connection diagram, if the figure if $Z_c = j\omega(-ESL)$, it can be offset by the parasitic inductance ESL, so we can

use in the forward series of two coupling inductance Z_a and Z_b method to achieve the purpose.

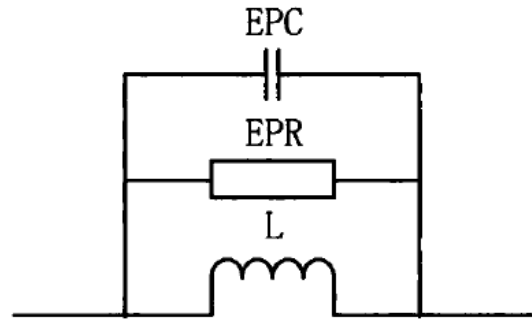

Figure 3. Inductive parasitic equivalent diagram

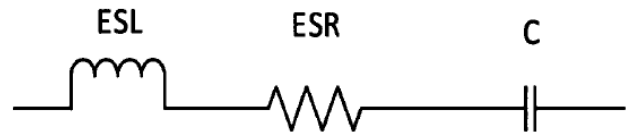

Figure 4. Capacitor parasitic equivalent diagram

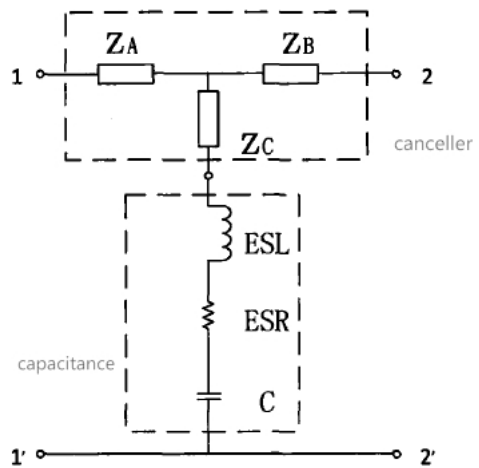

Figure 5. Parasitic inductance eliminator

3.2 Inductive Parasitic Capacitance Suppression

Figure 6 is the parasitic capacitance eliminator of the electrical connection diagram, if the parallel branch of the inductor equivalent to a size of-capacitance of the capacitor C, then the equivalent parasitic capacitance will be offset, to achieve the ideal high the purpose of frequency filtering. The specific approach is as shown in Figure 7 in the middle of the inductor to connect a capacitor C_a , contact on both sides of the coil winding coupling coefficient of 1, After decoupling, it is triangularly connected to transform, get $C_a = 4EPC$, which is the ideal suppression parasitic inductance suppression parameters, and finally get the actual circuit of the elimination device, as shown in Figure 8.

Table 1. Comparison of Two Filter Test Results

f/MHZ	1	2	5	10	20	50	100
traditional	-41dB	-45dB	49dB	-53dB	-40dB	-34dB	-29dB
improved	-52dB	-56dB	-61dB	-79dB	-61dB	-42dB	-36dB
effect	11dB	11dB	12dB	26dB	21dB	8dB	7dB

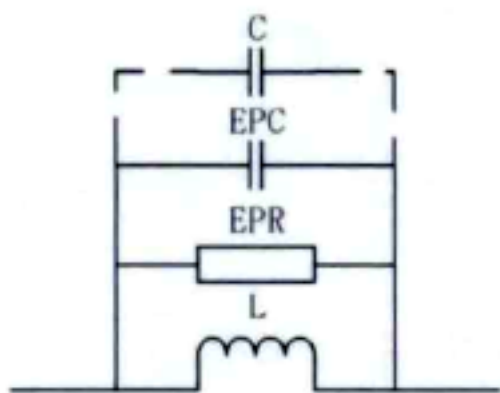

Figure 6. Parasitic capacitor eliminator

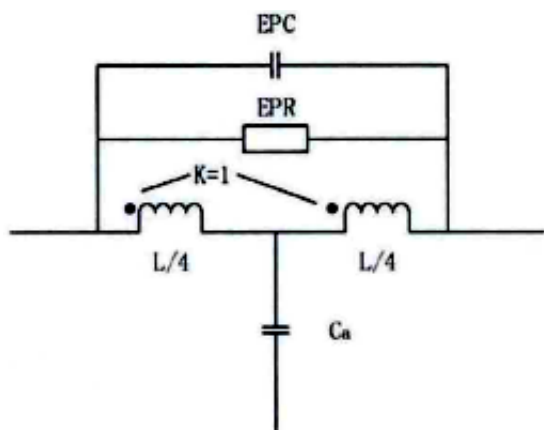

Figure 7. Access capacitance C_a

Using RS's ZKL vector machine to test, after the improved filter test results and the use of traditional filter test results as shown in Table 1.

4. Conclusion

Through the experimental results, we can clearly see the

design of fast transient pulse suppression filter, considering the "parasitic parameters" of the impact, and suppression of the parasitic inductance and parasitic capacitance in the design can significantly improves the filter The filtering effect of EFT / B plays an obvious role.

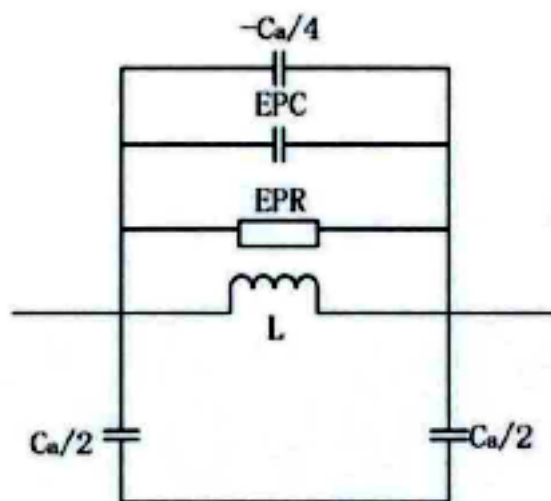

Figure 8. Eliminate the actual parameters of the eliminator

References

- [1] IEC61000-4-4. Electromagnetic-Compatibility Testing and Measurement Techniques, Electrical Fast Transient / burst Immunity Test[S]. 1995.
- [2] ROU TRAY A, PRADHAN A K, RAO K P. A novel kalman filter for frequency estimation of distorted signals in power systems[J]. IEEE Transactions on Instrumentation and Measurement, 2002,51(3): 469-479.
- [3] WIGGINS C M, NICKEL F S, HANEY A J. Mobile transient measurement system[J]. IEEE Symposium on EMC, Session2C,1987:42-54.